

PN: SRL169

## TECHNICAL SPECIFICATIONS

### Hook Twin SRL Connector

DUAL LEG SRD CONVERTER - a Carabiner with SRD Plastic Connector. Gate Strength 3600 lbs. Min breaking strength 5000 lbs. Meets or exceeds ANSI Z359.12-2009.

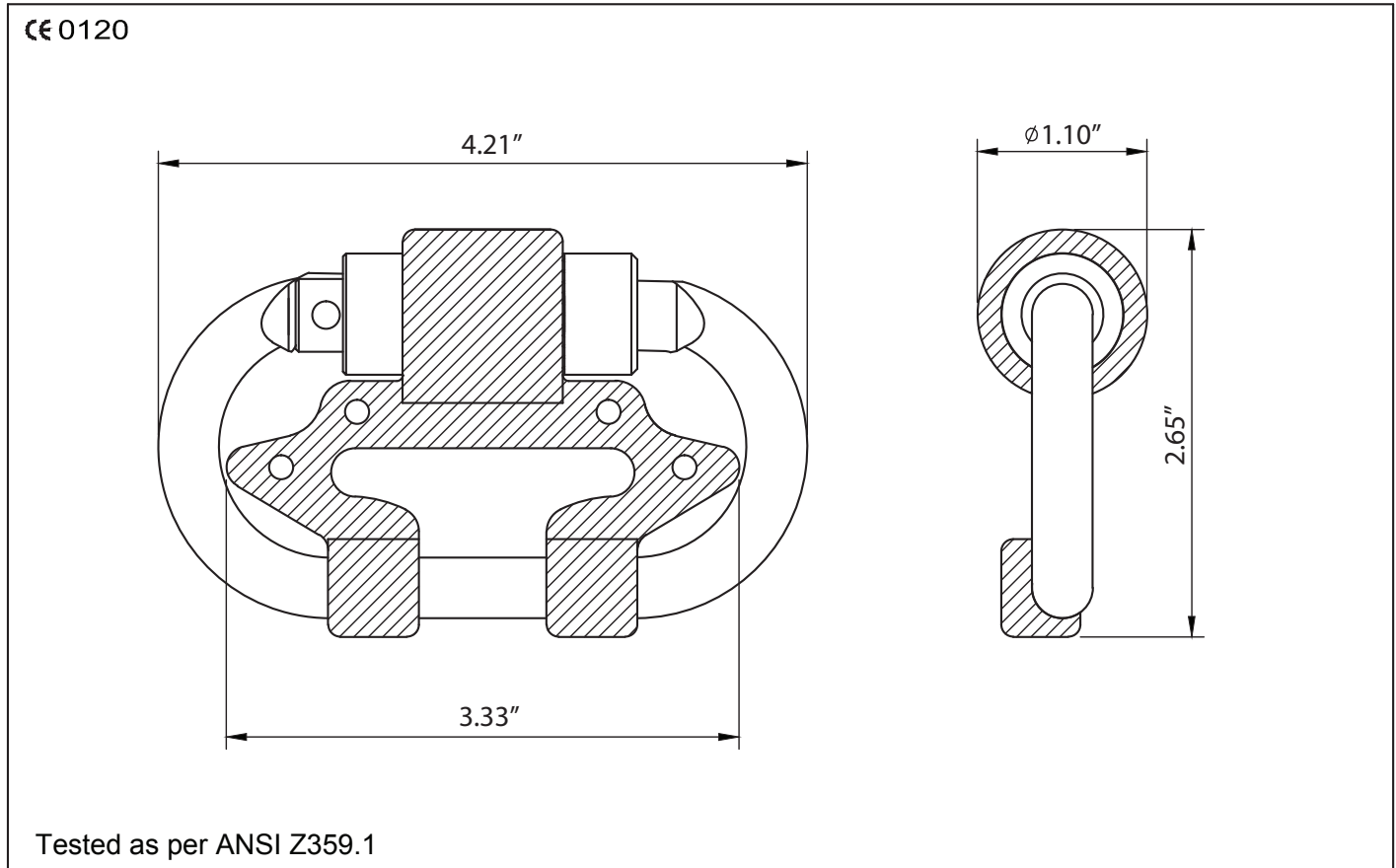

**DESIGN:** Ultimate solution to attach 2 SRD's directly with user's harness with no additional connector required.

**MATERIAL:** Alloy Steel  
Separator: High density polyethylene

**FINISH:** Yellow chromate

**MINIMUM BREAKING STRENGTH:** 23 kN (5170 lbs.)

**WEIGHT:** 0.385 lbs. ± 0.02 lbs. (175.0 gm ± 10.0 gm)