

## TECHNICAL SPECIFICATIONS

### SRD 100' Galvanized Cable with Small Hook

100' retractable galvanized cable, swivel top composite housing, 3/4" load indicator hook, 1/2" carabiner with tagline included. Blue housing. Meets or exceeds ANSI Z359.14-2014 Class B.

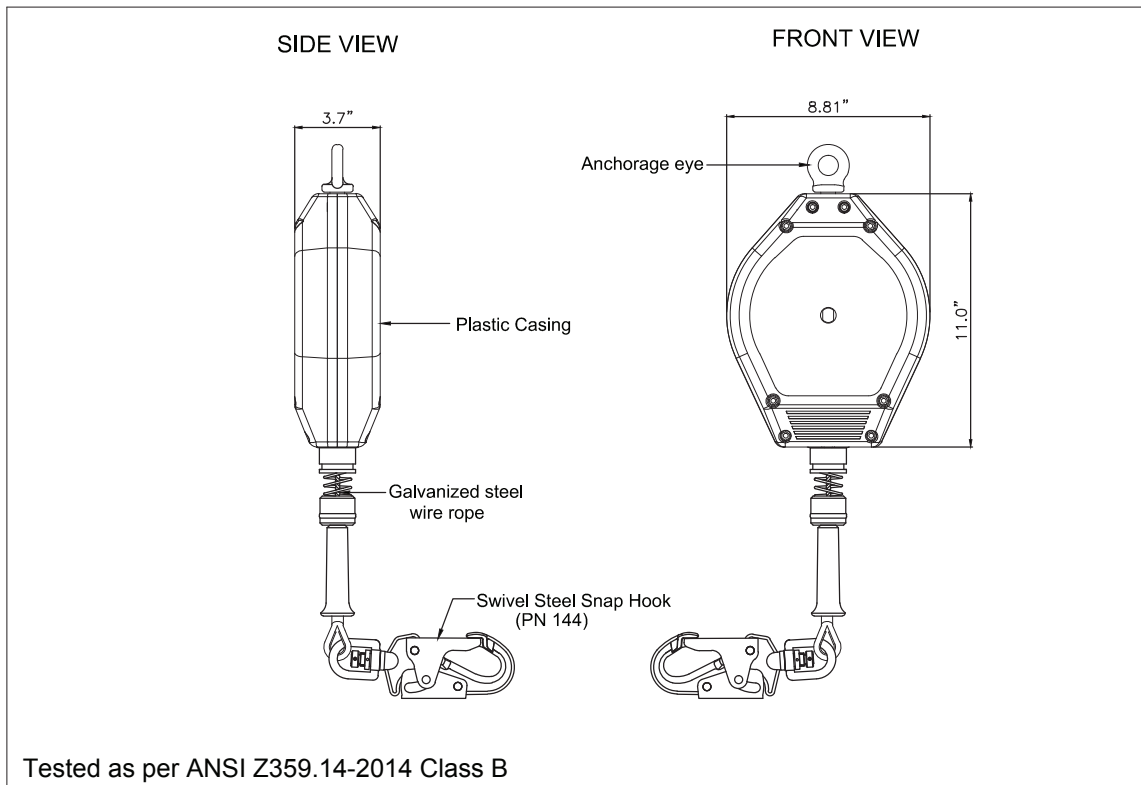

- PHYSICAL PARAMETERS:**
- Composite housing.
  - Robust & durable plastic casing.
  - Has swivel anchorage eye at anchorage end.
  - Swivel steel snap hook with load indicator at attachment end (as per ANSI Z359.12-2009; gate strength 3600 lbs.).
  - Galvanized steel wire rope (option of having S.S. wire rope available).

**LENGTH:** 100'

**CABLE:** 3/16" GAC  
 Material: Galvanized steel wire rope diameter of 3/16"  
 Minimum Breaking Strength: 3300 lbs.

**VITAL TEST COMPLIANCE:** Static Strength: 3000 lbs. for 1 minute.  
 Dynamic Strength: 300 lbs. mass subjected to a 4' free fall. SRD lock and remain lock until released.  
 Dynamic Performance: 282 lbs. mass subjected to a zero free fall with extension of 36" lifeline. Braking force less than 1800 lbs. Average braking force less than 900 lbs. and arrest distance less than 54".

**WEIGHT:** 28.49 lbs. ± 0.11 lbs.